

VL MINI / PRO / PROMAX



Innovative self-lifting stacker with 550 kg maximum capacity load

DESCRIPTION

The VL self-lifting stacker is an innovative and cutting-edge material handling equipment. It can load and unload pallets up to 550 kg in light commercial vehicles and trucks.

As the stacker lifts itself into the truck, it considerably reduces loading and unloading time and improves the operator's comfort.

FEATURES

- Safe and quick loading
- No additional help or equipment needed
- Three versions : MINI, PRO and PROMAX
- Prevents MSD (Musculoskeletal disorders)



EXCLUSIVE PARTNER **VANLIFT**





VLPROMAX

Load height: 1350 mm
 Overall dimensions (LxWxH): 1620x800x1770 mm
 Fork length: 1200 mm

VLPRO

Load height: 830 mm
 Overall dimensions (LxWxH): 1620x800x1200 mm
 Fork length: 1200 mm

VLMINI

Load height : 710 mm
 Overall dimensions (LxWxH): 1620x800x1080 mm
 Fork length : 1200 mm



Highlights



4.3" touch screen with multiple functions including weight indication, battery charge, etc.

Grease-free lifting system

Energy recovery when lowering of loads, high energy efficiency

Protection class IP 54

Full battery charge in only 3 h 30

Data recording, hour counter, auto shutdown on steep slopes



Charts

Lift cycles

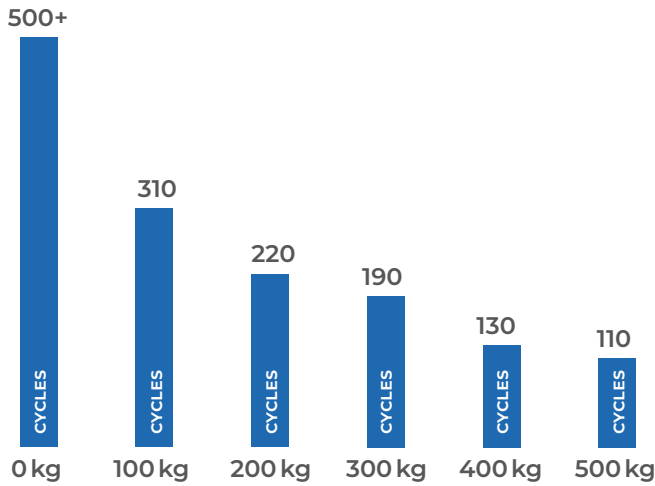

Load curve

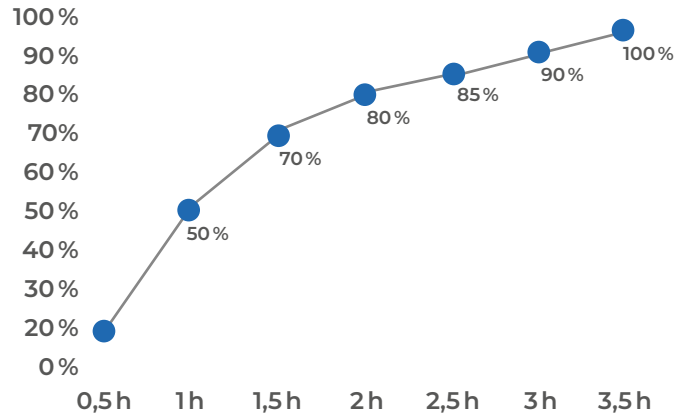

Power consumption

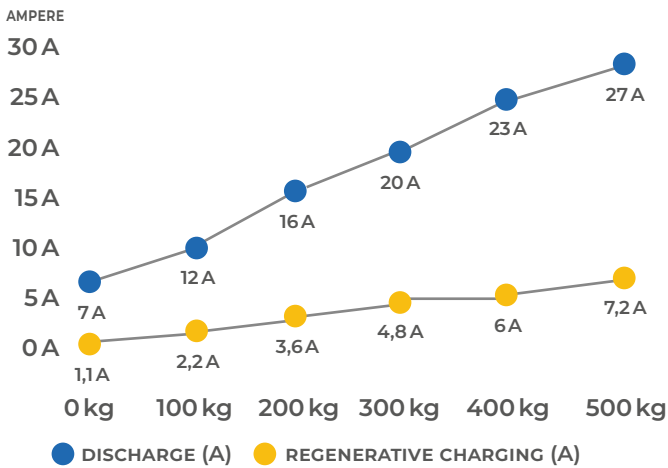

Thrust

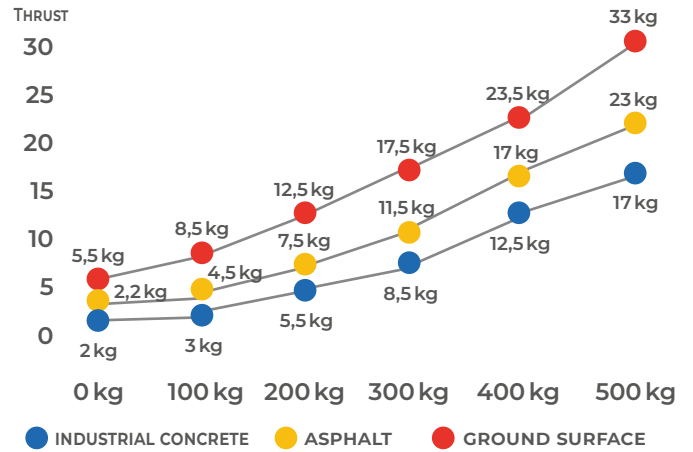

Photos and dimensions are not contractual. The manufacturer reserves the right to make any modification without notice, in order to improve the performance of the equipment.

Loading steps

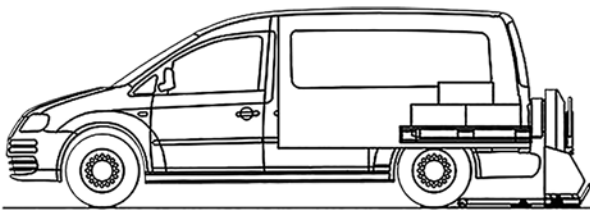

1 Pick up the load and lift the pallet

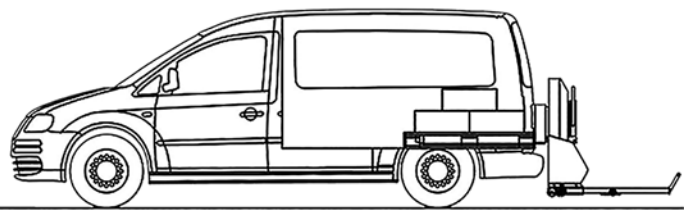

2 Lay down the pallet on the truck, lower the forks, and pull out the latch

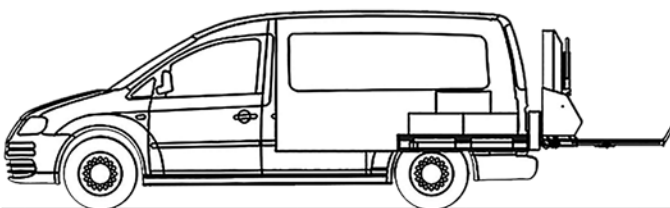

3 Continue pressing the lower button to lift the stacker, push the latch

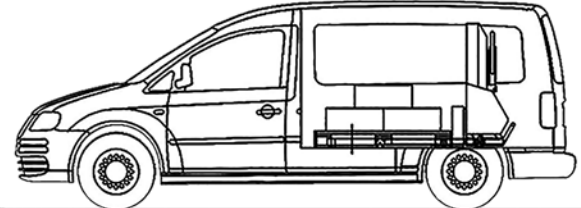

4 Place the stacker in the truck

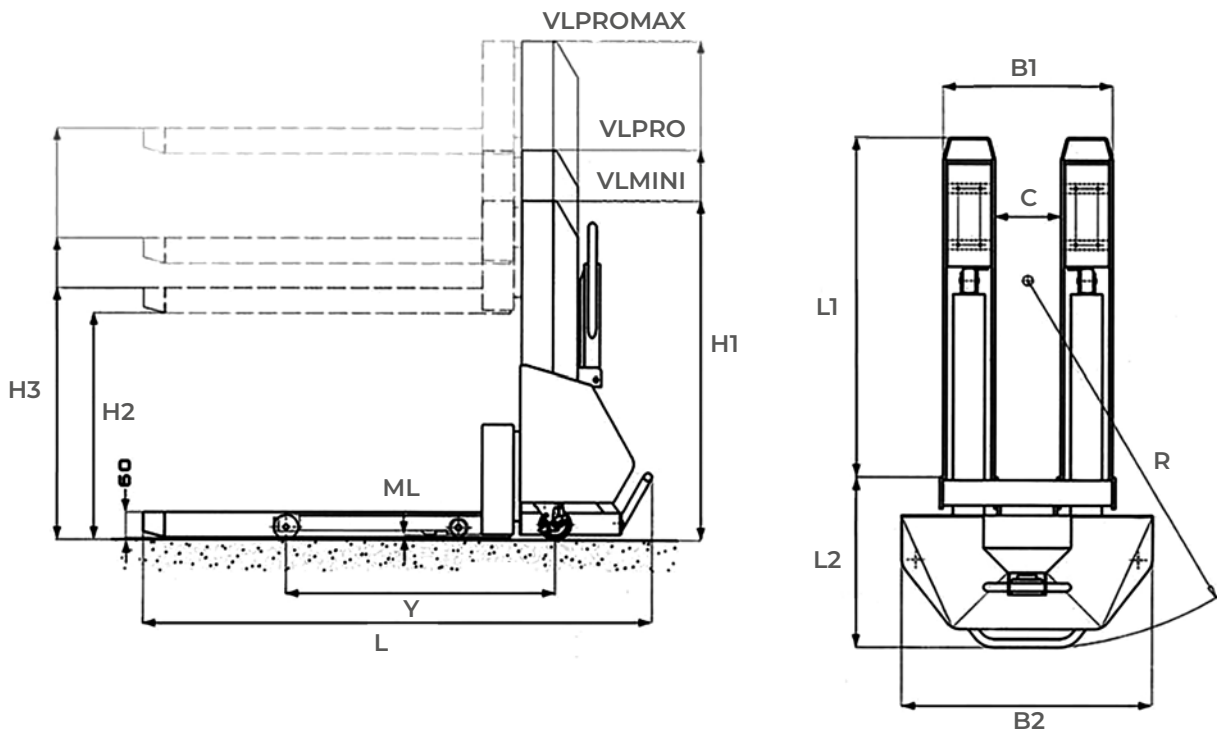

Specifications		Product Reference ♦ Model	VLMINI	VLPRO	VLPROMAX
	Load capacity	kg	550	550	550
	Wheelbase	mm	860	860	860
Weight	Total net weight	kg	180	200	220
Dimensions	Overall dimensions (LxWxH)	mm	1620x800x1080	1620x800x1200	1620x800x1770
	Load height	mm	710	830	1350
	Fork length	mm	1200	1200	1200
	Width across forks	mm	540	540	540
	Forks inner width	mm	210	210	210
	Front axle to fork face length L2	mm	420	420	420
	Turning radius	mm	1180	1180	1180
Electrical system	Lift motor	W	800	800	800
	Battery	V/Ah	48/7,5	48/7,5	48/7,5