



# TP201YS



## Semi-automatic side-seal stainless steel strapping machine

### FEATURES

- AISI 304 stainless steel construction
- Tension control
- Adjustable height between 375 and 825 mm
- Reliable, fast, quiet
- The table design ensures all mechanical components are protected
- Electrical parts are splash-proof

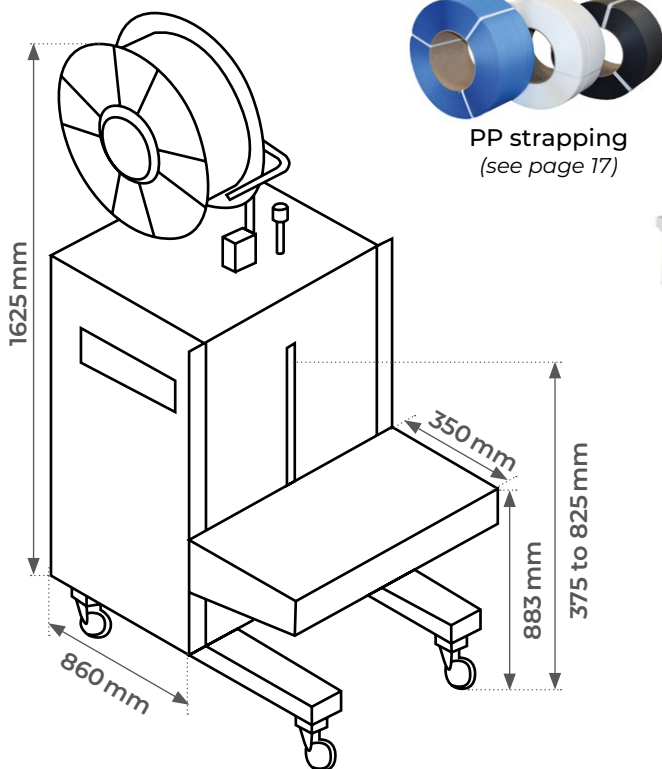

Model		TP201YS
Exterior width	mm	675
Depth	mm	860
Height	mm	1625
Strapping width	mm	6/9/12/15,5
Strapping mandrel	mm	Ø200
Parcel min. dimensions	mm	60x30
Power supply	V	220 single-phase
Tension force	kg	15 to 45
Cycle speed	s	2,5
Weight	kg	125

**IDEAL FOR MOIST AND CORROSIVE ENVIRONMENT, OYSTER-FARMING, FOOD PROCESSING**

