

# TMD-C46U



## Professional top/bottom belt case sealing machine

### FEATURES

- Semi-automatic case sealer
- Top/bottom drive belts
- Fast and easy height and width adjustment by crank handle
- Top and bottom sealing
- Effortless format adjustment
- Instream and downstream free roller conveyor
- Fitted with four swivel castors with brake

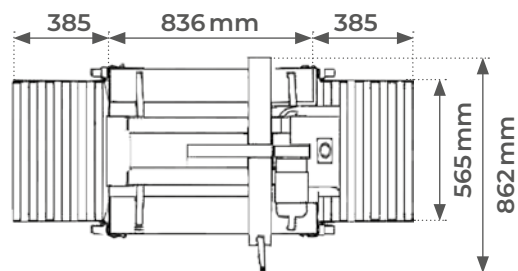
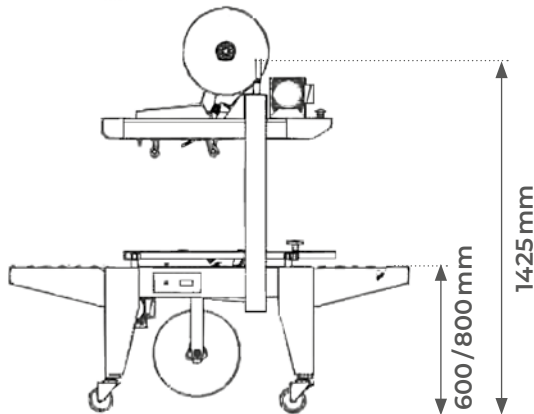
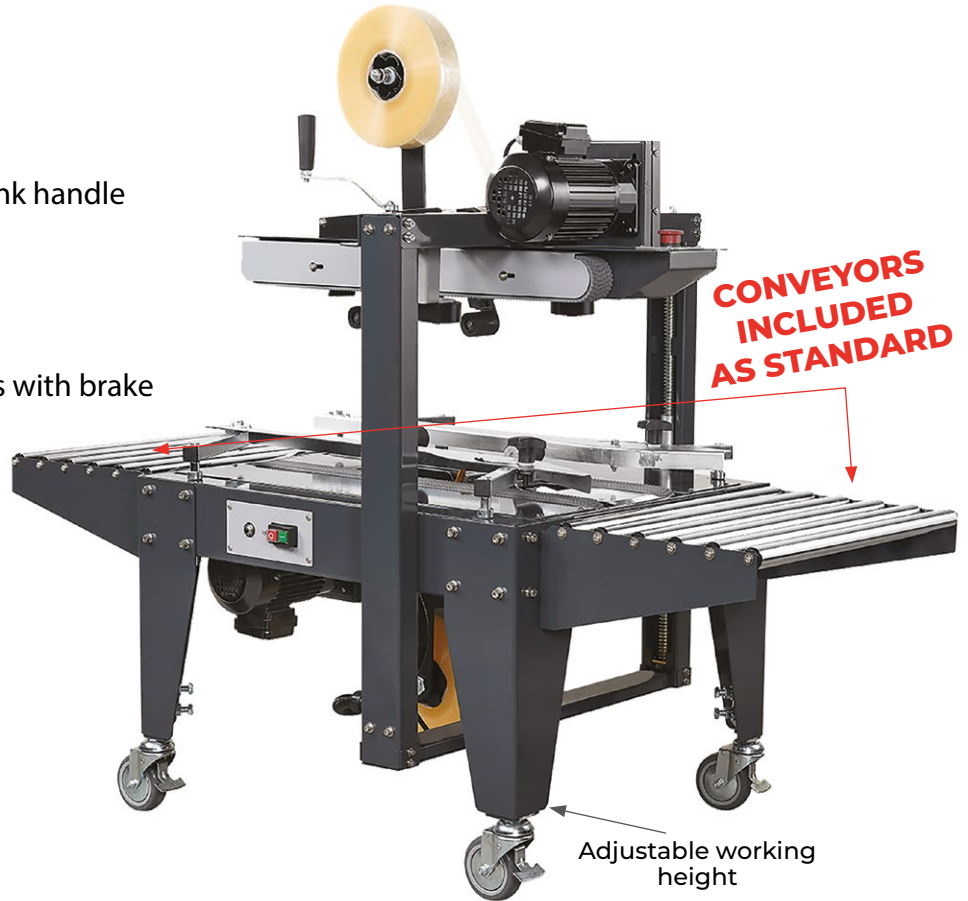

| Model                  |       | TMD-C46U                          |
|------------------------|-------|-----------------------------------|
| Adhesive tape width    | mm    | 50 (75 in option)                 |
| Box dimensions (LxWxH) | mm    | 150 to ∞ / 150 to 500 / 80 to 500 |
| Working height         | mm    | from 600 to 800                   |
| Speed                  | m/min | 20                                |
| Power supply           | V/Hz  | 220 single-phase / 50             |
| Engine power           | W     | 450                               |
| Dimensions (LxWxH)     | mm    | 1606x862x1425                     |
| Weight                 | kg    | 124                               |



Control panel