



# TMD-C26U



## Professional side belt case sealing machine

### FEATURES

- Semi-automatic case sealer
- Automatic or manual launch
- Side feed belts
- Quick and easy cartons height and width adjustment by crank handle
- Top and bottom sealing
- Fitted with four swivel castors with brakes

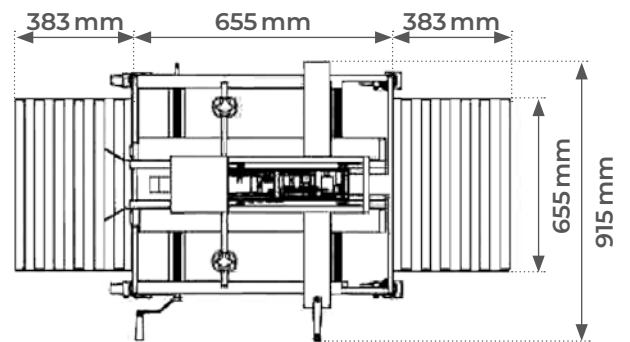
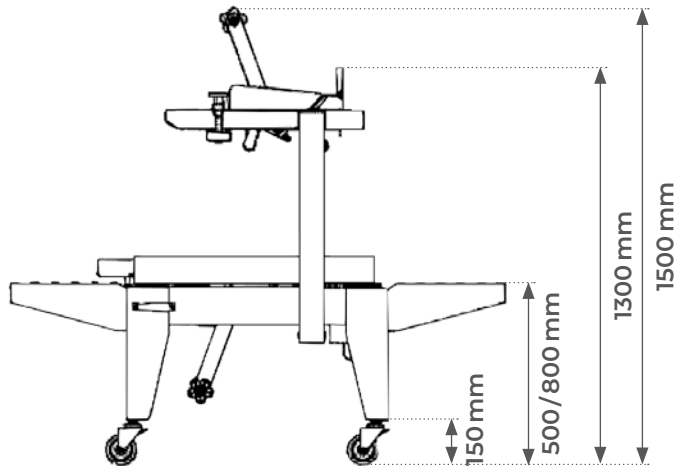
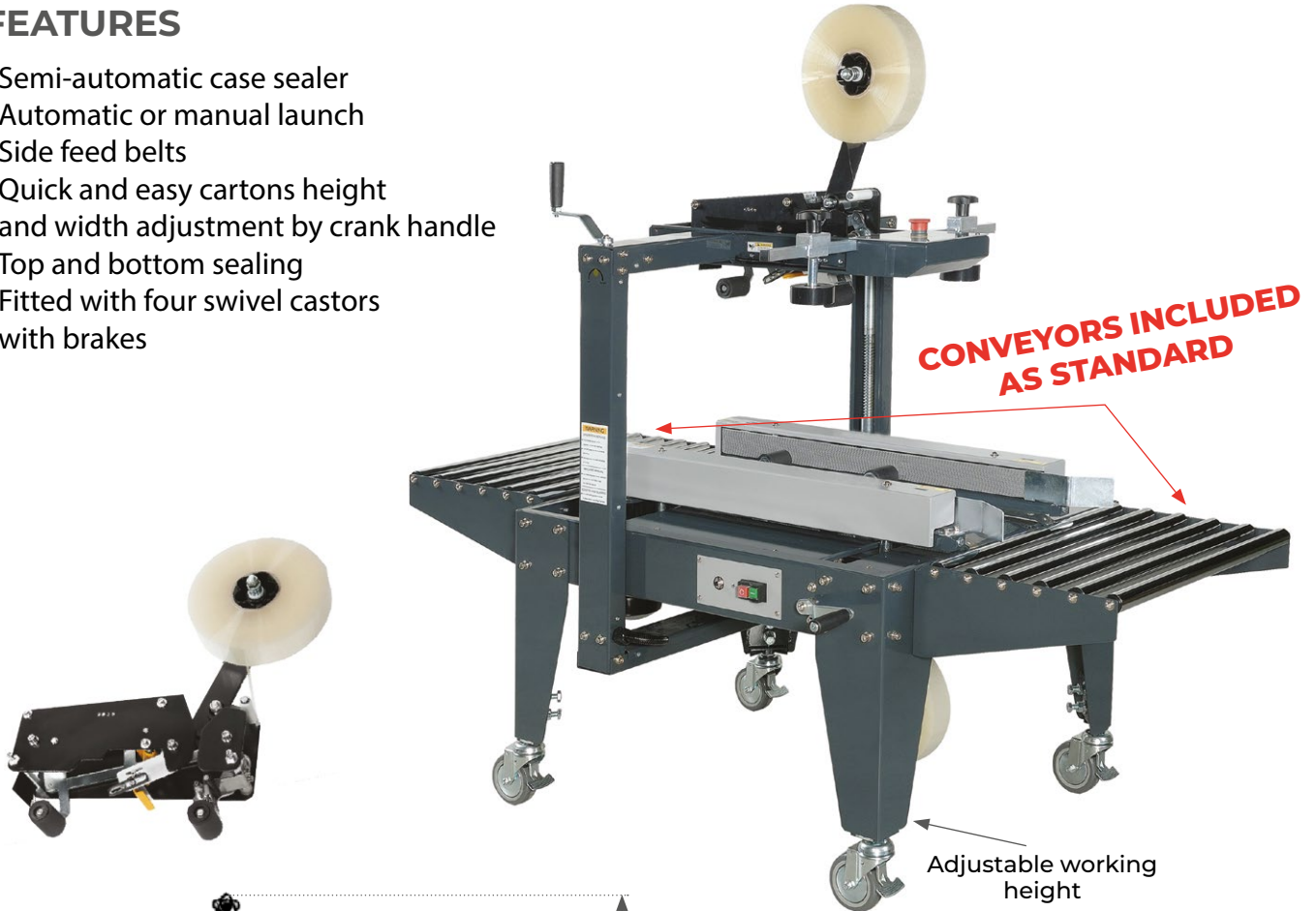

Model		TMD-C26U
Adhesive tape width	mm	50 (75 in option)
Box dimensions (LxWxH)	mm	150 to ∞ / 150 to 500 / 80 to 500
Speed	m/min	20
Engine power	W	450
Dimensions (LxWxH)	mm	1421 x 915 x 1500
Weight	kg	131



Control panel