

SCP05M



Pivoting counterbalance shop crane 500 kg

FEATURES

- Versatile and easy to operate
- Load capacity: 500 kg capacity
- Ballast included
- 360° rotating mast
- Extendable boom adjustable in four positions
- Delivered with shackle and 360° swivel hook
- Epoxy paint coating
- Three-year warranty

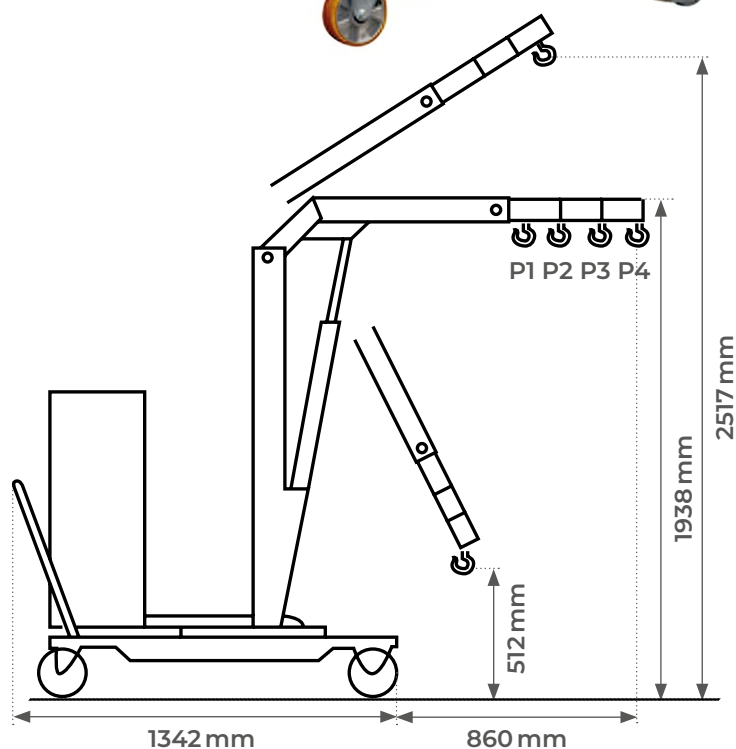
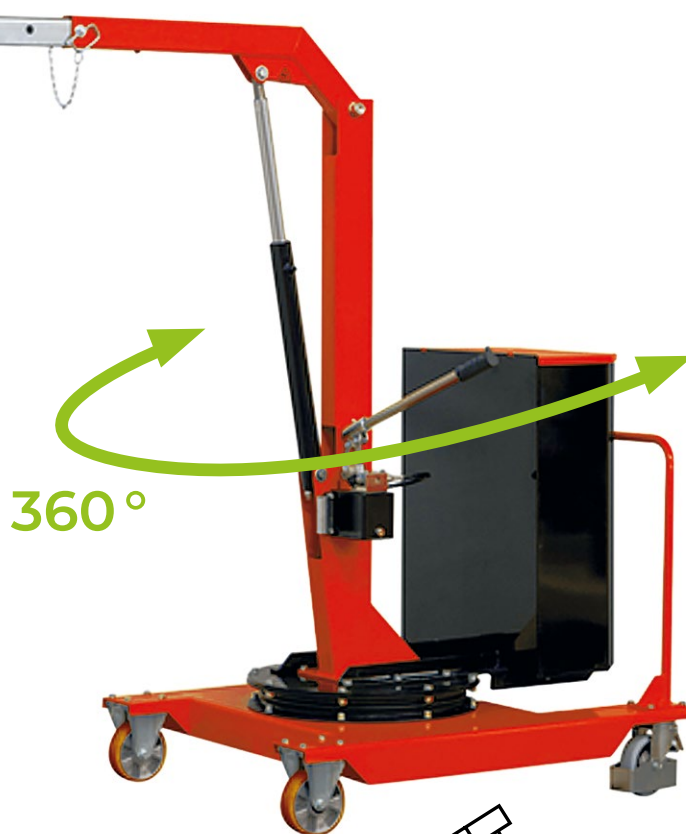
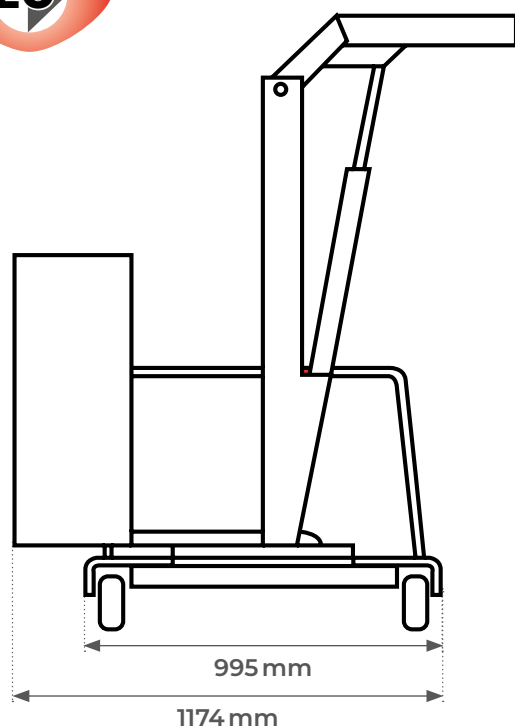

EXCLUSIVE
PARTNER



Model		SCP05M
Load capacity	kg	500
Overall dimensions (L x W x H)	mm	1772 x 1174 x 1938
Wheels	mm	Ø 200
Total weight	kg	608

Position		1	2	3	4
Length	mm	455	590	725	860
Load capacity	kg	500	420	370	320