

SCH



Manual counterbalance shop crane 550 and 750 kg

FEATURES

- Load capacity: up to 750 kg
- Extendable boom telescopes out for greater reach allowing to avoid troublesome obstacles
- Sturdy and practical construction
- 360° swivel hook
- Fitted with fork sleeves for easy carriage
- Double pump quick lift
- Ballast included

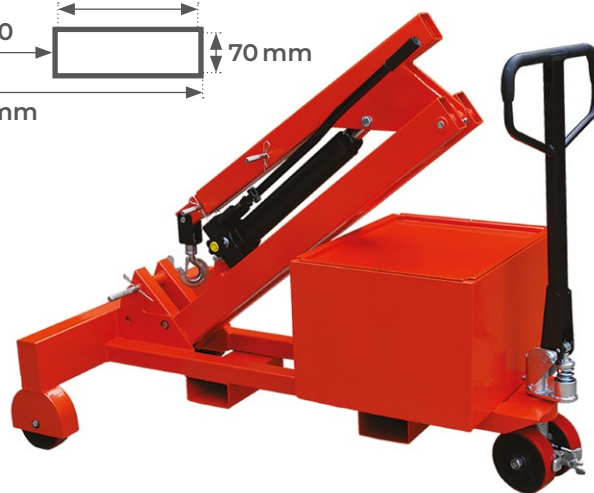
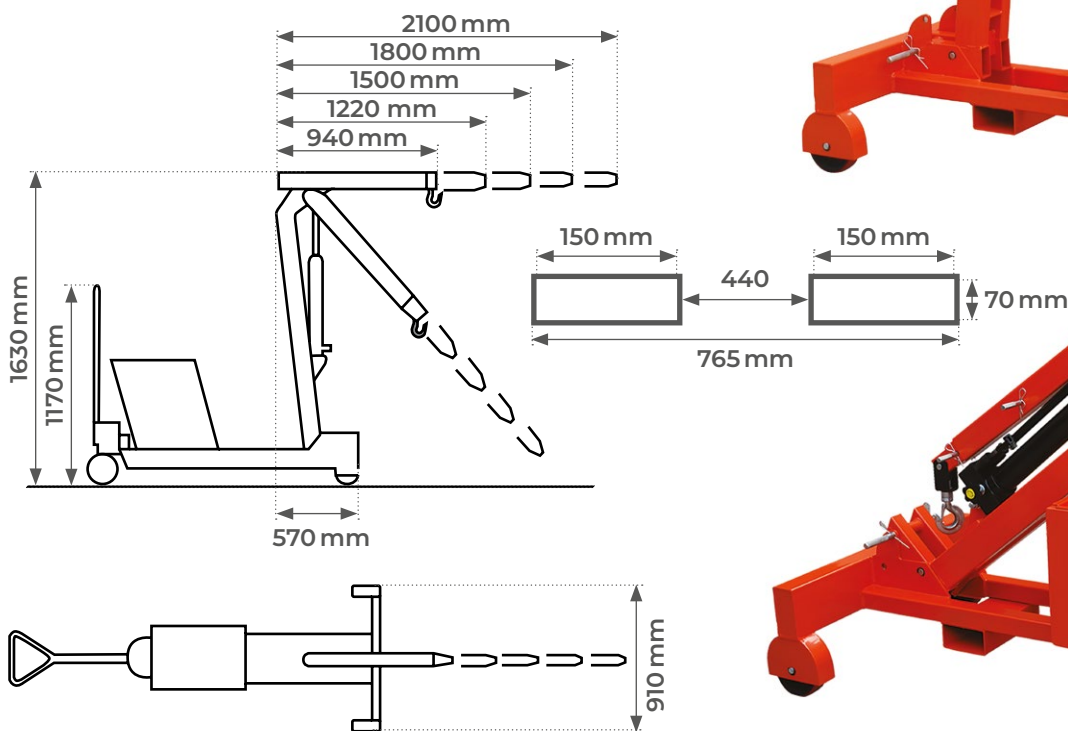

Model		SCH05	SCH075
Load capacity	kg	550	750
Overall dimensions (L x W x H)	mm	1800 x 910 x 1400	1800 x 910 x 1400
Max. capacity offset boom = 925	kg	550	750
Max. capacity offset boom = 1210	kg	450	500
Max. capacity offset boom = 1500	kg	350	380
Max. capacity offset boom = 1800	kg	250	260
Max. capacity offset boom = 2080	kg	150	200
Hydraulic pump	kg	double action 1000 kg	double action 1000 kg
Offset boom min / max	mm	930 / 2080	930 / 2080
Max. height with telescopic arm extended	mm	2750	2750
Polyurethane wheels	mm	Ø 180	Ø 180
Crane weight without / with counterweight	kg	180 / 470	180 / 520