

SAC30



Cylinder tank hand truck with lifting hoist

FEATURES

- Ideal for transporting and lifting cylinder tanks or other instruments
- Robust steel construction
- Ø400 mm pneumatic wheels
- Cable locking mechanism
- Easy to handle
- Epoxy coat and galvanized steel securing gate

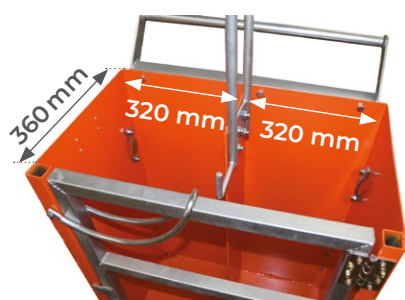
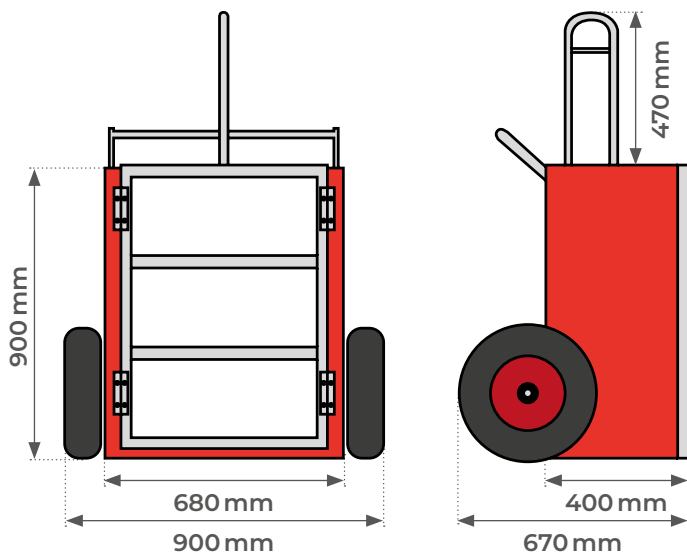
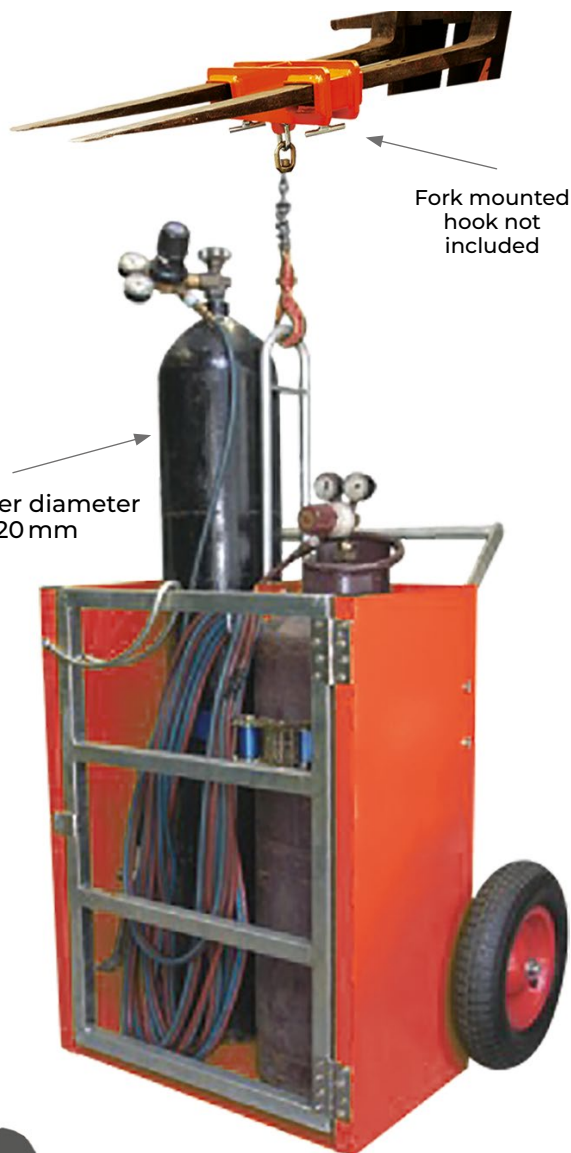

Model		SAC30
Load capacity	kg	250
Type		2 cylinders
Overall dimensions (WxDxH)	mm	900x670x1370
Cylinder diameter	mm	Ø320
Pneumatic wheels	mm	Ø400
Weight	kg	77