

ORBIT



Motorized pivoting counterbalance shop crane 200 and 500 kg

FEATURES

- The smallest in its category
- Fully electric: lifting, extension, pivoting, traveling
- Excellent traction quality and exceptional steering angle
- 210° pivoting and up to 2000 mm extension
- Automatic overload safety device
- Waterproof AGM battery and integrated charger
- Arm extension locking system
- Complies with all safety standards, emergency stop, differential, buzzer, shut-off valve, etc.

ELECTRIC LIFT, EXTENSION AND PIVOTING, MOTORIZED TRAVELING

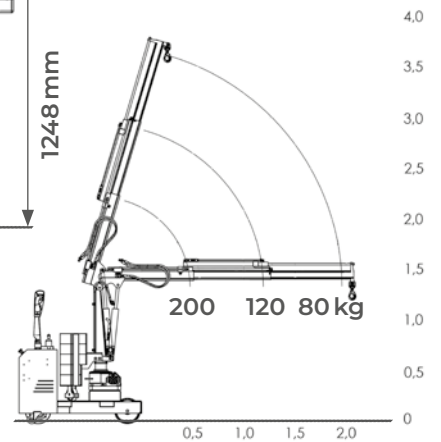
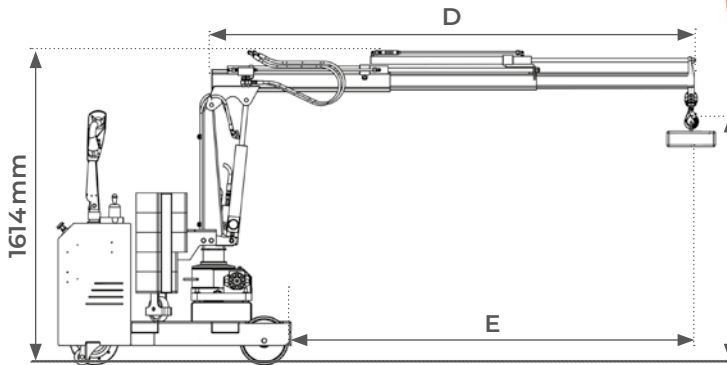
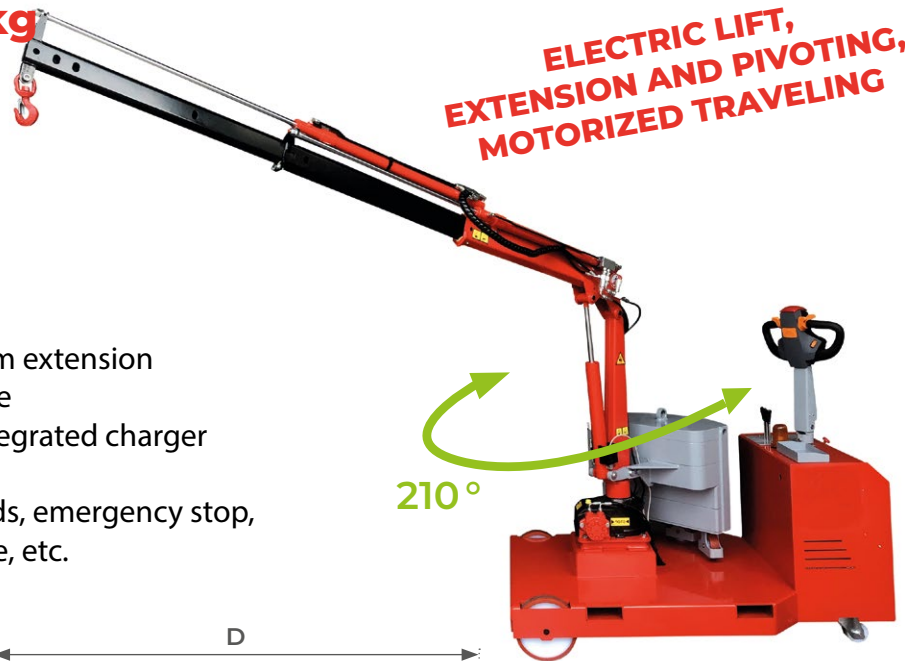

EXCLUSIVE PARTNER



All control buttons are grouped

Model		ORBIT200E	ORBIT500E
Folded boom capacity	kg	200	500
Extended boom max. capacity	kg	80	200
Overall dimensions (L x W x H)	mm	1200 x 800 x 1400	1400 x 990 x 1400
Min./max. boom length	D mm	993 / 2470	993 / 2470
Extension	E mm	583 / 2050	487 / 1963
Traction motor	Kw	1,2	1,2
Lift motor	Kw	0,8	0,8
AGM battery	V/A	2 x 12 / 2 x 120	2 x 12 / 2 x 120
Charger	V/A	24 / 12	24 / 12
Weight	kg	800	1100

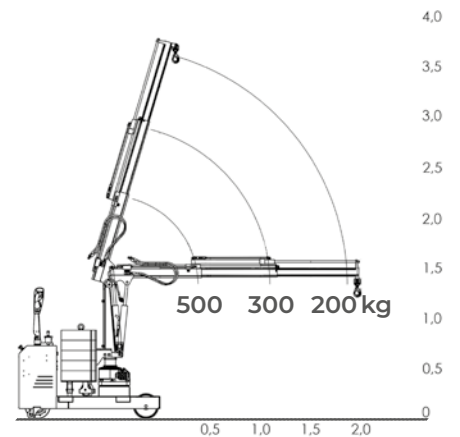

ORBIT500E