

MF

Support arm for MB electric hoist 250 and 600 kg

FEATURES

- Load capacity: 250 and 600 kg
- Suitable for MB electric hoist
- Mast and hoist not included

MAST NOT INCLUDED

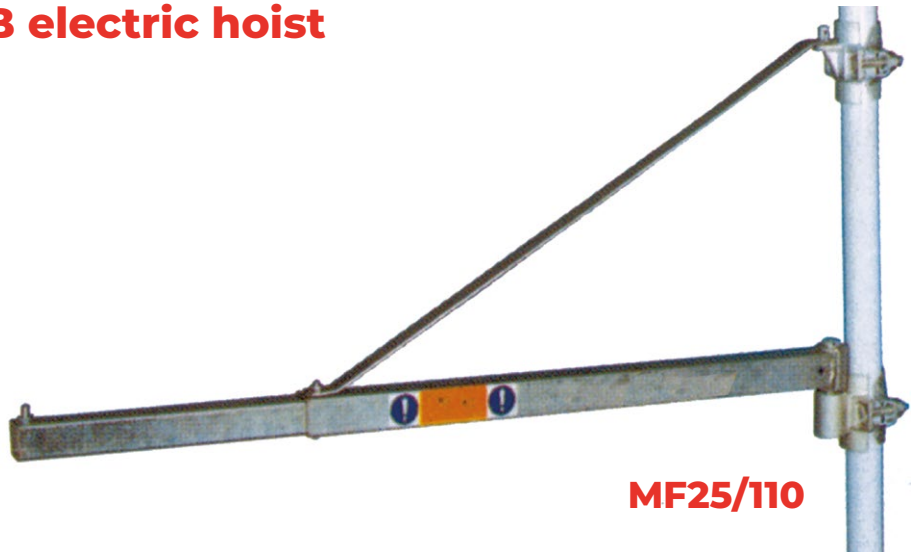

MF25/110

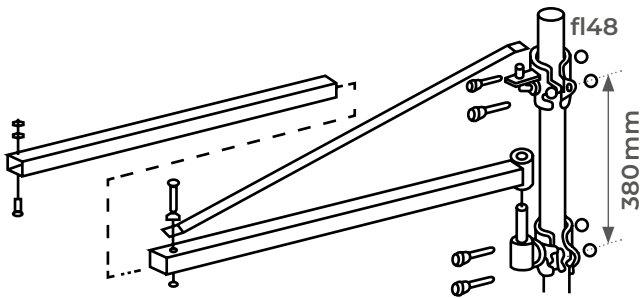

Suited for MB electric hoist

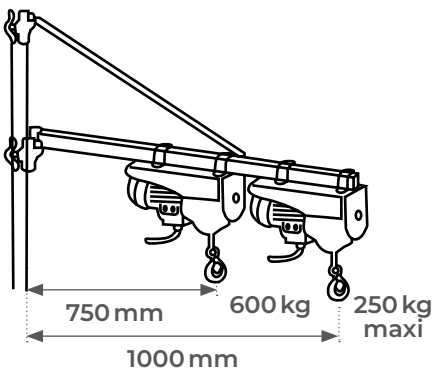

MF60/75

Model		MF25/110	MF60/75
Max. capacity	kg	250	600
Max. range	mm	1100	750
Weight	kg	5	6,5