

# MB



## Mini electric hoist 125 to 1000 kg

### FEATURES

- High-end motor and gearbox
- Standard limit switch
- Control unit
- Compact
- Hauling system
- Load cycles: 6 per hour
- Rest period: 8 min. between cycles
- 2 m remote control unit cable
- Delivered with two fixing hoops



**MB500**



**MB250**

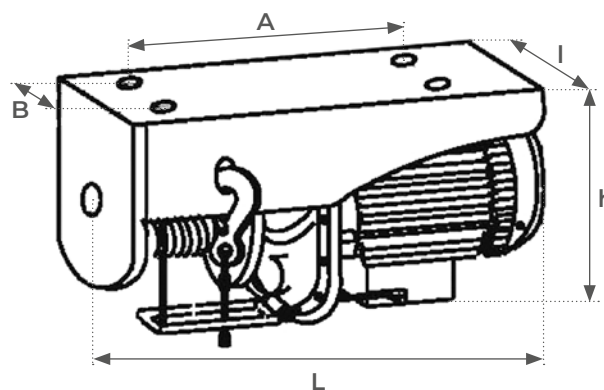

| Model                            |       | MB250       | MB500         | MB1000      |
|----------------------------------|-------|-------------|---------------|-------------|
| Load capacity in 6 m / 2 strands | kg    | 250         | 500           | 1000        |
| Load capacity in 12 m / 1 strand | kg    | 125         | 250           | 500         |
| Overall dimensions (LxWxH)       | mm    | 325x131x155 | 371,5x145x174 | 482x170x250 |
| Center distance (A x B)          | mm    | 190x90      | 190x100       | 250x110     |
| Number of strands                |       | 1 - 2       | 1 - 2         | 1 - 2       |
| Voltage                          | V     | 220         | 220           | 220         |
| Power                            | w     | 500         | 900           | 1600        |
| Lifting speed                    | m/min | 10 - 5      | 10 - 5        | 8 - 4       |
| Cable length                     | m     | 12 - 6      | 12 - 6        | 12 - 6      |
| Weight                           | kg    | 12,5        | 20            | 31          |