

EH



380 volts Electric chain hoist 250 to 2000 kg

FEATURES

- Robust, compact, lightweight and powerful
- Load limiter
- Electromagnetic spring pressure brake
- Water resistant motor housing
- Gear train lubricated for life
- Conforms to ASME / ANSI B30 EN B10 NEMA 12 standards
- Limit switch
- IP 54 protection
- 3-phase 380V
- 3 m HOL
- Two lifting speeds
- 3 m remote control unit cable



IN OPTION

Hoist trolley for
EH502, EH1001
and EH2002

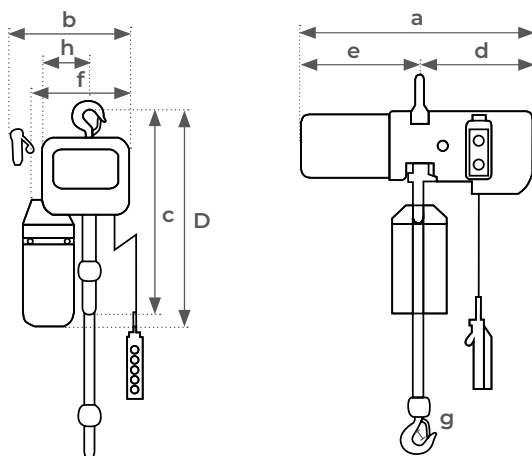

Model		EH251				EH502				EH1001				EH2002			
		3M	3M	6M	9M	12M	3M	6M	9M	12M	3M	6M	9M	12M	3M	6M	9M
Load capacity	kg	250				500				1000				2000			
Lift height	m	3				3				3				3			
Fast / slow lifting speed	m/min	14/3,5				7,6/2,5				5/1,7				2,5/0,85			
Classification		M5				M5				M5				M5			
Number of strands		1				1				1				2			
Chain	mm	Ø5x15				Ø6,3x19				Ø8x24				Ø8x24			
a	mm	592				610				630				630			
b	mm	304				304				304				304			
c	mm	505				520				550				700			
d	mm	273				273				273				273			
e	mm	337				337				357				357			
f	mm	255				255				255				255			
g	mm	24				31				38				45			
h	mm	120				120				120				120			
D	mm	620				620				640				680			
Engine power fast / slow	kw	0,85/0,21				0,9/0,3				1,1/0,37				1,1/0,37			
Engine power supply	V	380 three-phase				380 three-phase				380 three-phase				380 three-phase			
Frequency	Hz	50				50				50				50			
Housing power supply	v	24				24				24				24			
Weight	kg	54	57	59	62	64	66	70	75	79	81	90	98	107			